

Double-Layer Capacitors in Cylindrical Metal Case with very High Capacitances in the Farad Range

Special Features

- Storage capacitors with very high capacitance values of 110 F and 200 F and a rated voltage of 2.5 VDC
- Discharge current up to 400 A
- Maintenance-free
- With cylindrical metal case
- Series connection possible
- According to RoHS 2002/95/EC

Typical Applications

Suitable for support, protection or replacement of batteries in the field of new traction technologies in

- Automotive
- Railway technology
- Wind power systems
- Uninterruptible power systems (UPS)

Construction

Internal construction:

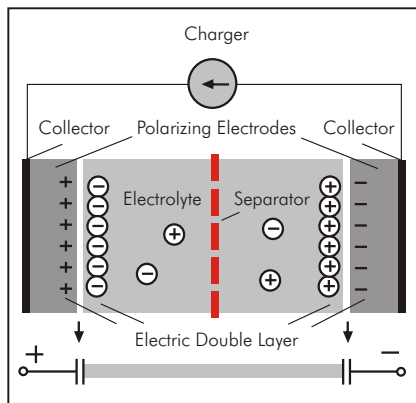

Encapsulation:

Cylindrical aluminium case

Terminations:

Lug terminals: Solder pin / 4

Marking:

Colour: Black. Marking: Gold

1) Requirements:

$I\Delta C/CrI \leq 30\%$, $ESR \leq 2$ times specified limit, $I_{leak} \leq 2$ times of initial value.

2) Test conditions:

$I\Delta C/CrI \leq 30\%$, $ESR \leq 2$ times specified limit, $I_{leak} \leq 2$ times of initial value (1. cycle: charging to V_R , 30 sec rest, discharging to $V_R/2$, 30 sec rest).

Technical Data

Rated capacitance:	CR	110 F	200 F
Capacitance tolerance:	-	$\pm 20\%$	$\pm 20\%$
Rated voltage:	UR	2.5 V	2.5 V
Rated current:	IC	30 A	45 A
Pulse current:	IP	up to 220 A	up to 400 A
Internal resistance:	RDC	11 m Ω	6 m Ω
Max. energy: $\pm 20\%$	E _{max.}	344 J	625 J
Operating temperature:	T _{op}	-30° C ... +65° C	
Storage temperature:	T _{st}	-40° C ... +70° C	
Weight:	m	40 g	65 g
Volume:	v	0.034 l	0.056 l

Additional Data

Case:	-	Al99.5	Al99.5
Lug terminals:	-	Solder pin/4	Solder pin/4

Comparative Data

Lifetime:			
in hours ¹⁾	h	90 000	90 000
in cycles ²⁾	Cycles	500 000	500 000
Energy density:			
gravimetric	E _d	2.4 Wh/kg	2.7 Wh/kg
volumetric	E _v	2.8 Wh/l	3.1 Wh/l

