

1 Form A Solid State Relay

Features

- Maximum R_{ON} 5 Ω
- Load voltage 60 V
- Load current 100 mA
- Isolation test voltage 1500 V_{RMS}
- Small 4 pin SOP package
- Clean bounce free switching
- TTL/CMOS compatible input
- High reliability hybrid receptor
- Available on tape and reel
- Lead (Pb)-free component
- Component in accordance to RoHS 2002/95/EC and WEEE 2002/96/EC



20050

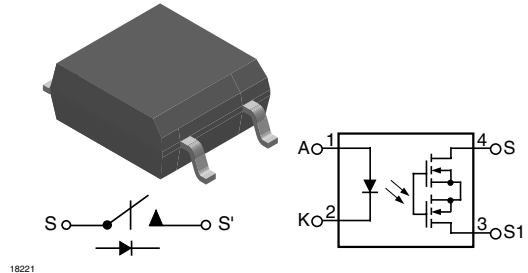

Agency Approvals

- UL File No. E300068 system code K
- CUL File No. E300068
- VDE DIN EN 60747-5-2 (VDE0884)

Description

The VO1400AEFTR is an optically isolated 1 Form A solid-state relay in a surface mount 4 pin SOP package.

Applications

- Security Systems
- Instrumentation
- Industrial controls

Order Information

Part	Remarks
VO1400AEFTR	Tape and Reel, SOP-4

Absolute Maximum Ratings

$T_{amb} = 25^\circ\text{C}$, unless otherwise specified

Stresses in excess of the absolute Maximum Ratings can cause permanent damage to the device. Functional operation of the device is not implied at these or any other conditions in excess of those given in the operational sections of this document. Exposure to absolute Maximum Rating for extended periods of the time can adversely affect reliability.

Input

Parameter	Test condition	Symbol	Value	Unit
LED continuous forward current		I_F	50	mA
LED reverse voltage		V_R	5.0	V



Output

Parameter	Test condition	Symbol	Value	Unit
DC or peak AC load voltage		V_L	60	V

SSR

Parameter	Test condition	Symbol	Value	Unit
Total power dissipation		P_{diss}	400	mW
Ambient temperature range		T_{amb}	- 40 to + 85	°C
Storage temperature range		T_{stg}	- 40 to + 125	°C
Soldering temperature	$t \leq 10$ s max	T_{sld}	260	°C
Isolation test voltage	for 1.0 s	V_{ISO}	1500	V_{RMS}

Absolute Maximum Rating Curve

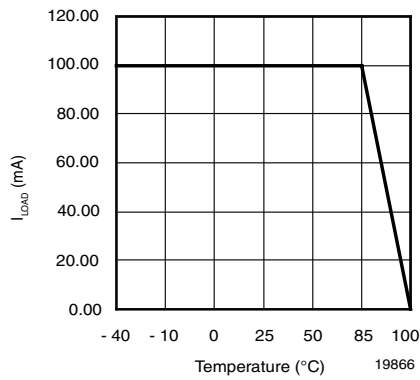
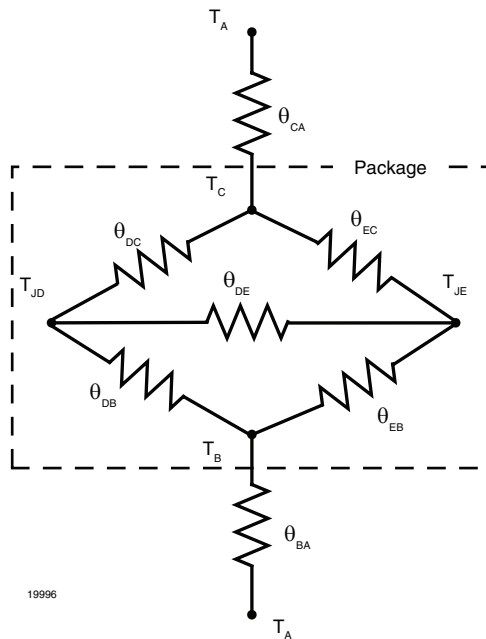

Figure 1. I_{LOAD} vs Temperature

Thermal Characteristics

The thermal model is represented in the thermal network below. Each resistance value given in this model can be used to calculate the temperatures at each node for a given operating condition. The thermal resistance from board to ambient will be dependent on the type of PCB, layout and thickness of copper traces. For a detailed explanation of the thermal model, please reference Vishay's Thermal Characteristics of Optocouplers Application note.

Parameter	Test condition	Symbol	Value	Unit
LED Power dissipation	at 25 °C	P_{diss}	60	mW
Output Power dissipation	at 25 °C	P_{diss}	50	mW
Total Power dissipation	at 25 °C	P_{tot}	110	mW
Maximum LED junction temperature		T_{jmax}	125	°C
Maximum output die junction temperature		T_{jmax}	125	°C
Thermal resistance, Junction Emitter to Board		θ_{JEB}	114	°C/W
Thermal resistance, Junction Emitter to Case		θ_{JEC}	99	°C/W
Thermal resistance, Junction Detector to Board		θ_{JDB}	60	°C/W
Thermal resistance, Junction Detector to Case		θ_{JDC}	80	°C/W
Thermal resistance, Junction Emitter to Junction Detector		θ_{JED}	115	°C/W
Thermal resistance, Case to Ambient		θ_{CA}	2396	°C/W



Electrical Characteristics

$T_{amb} = 25\text{ }^{\circ}\text{C}$

Minimum and maximum values are testing requirements. Typical values are characteristics of the device and are the result of engineering evaluation. Typical values are for information only and are not part of the testing requirements.

Input

Parameter	Test condition	Symbol	Min	Typ.	Max	Unit
LED forward current, switch turn-on	$I_L = 100\text{ mA}$, $V_L \leq 0.5\text{ V}$ $t = 10\text{ ms}$	I_{Fon}	0.3	1.0	3.2	mA
LED forward current for switch to remain off	$V_L = 60\text{ V}$	I_{Foff}	100	150		μA
Input reverse current	$V_R = 5\text{ V}$	I_R		0.001	10	μA
LED forward voltage	$I_F = 5\text{ mA}$	V_F	0.8	1.1	1.4	V
LED reverse voltage	$I_R = 10\text{ }\mu\text{A}$	V_R	5	40		V

Output

Parameter	Test condition	Symbol	Min	Typ.	Max	Unit
Peak load voltage		V_L			60	V
Load current AC peak	$I_F = 2\text{ mA}$	I_L			100	mA
Peak load current	10 ms	I_{LPK}		2.5	350	mA
ON- Resistance	$I_F = 10\text{ mA}$, $I_L = 100\text{ mA}$	R_{ON}		2.3	5	Ω
Off-state leakage current	$I_F = 0\text{ mA}$, $V_L = 60\text{ V}$	I_{LEAK}		0.002	1	μA

Switching Characteristics

Parameter	Test condition	Symbol	Min	Typ.	Max	Unit
Turn-on time	$I_F = 10\text{ mA}$, $V_L = 20\text{ V}$, $I_L = 100\text{ mA}$	t_{on}		52	500	μs
Turn-off time	$I_F = 10\text{ mA}$, $V_L = 20\text{ V}$, $I_L = 100\text{ mA}$	t_{on}		36	500	μs

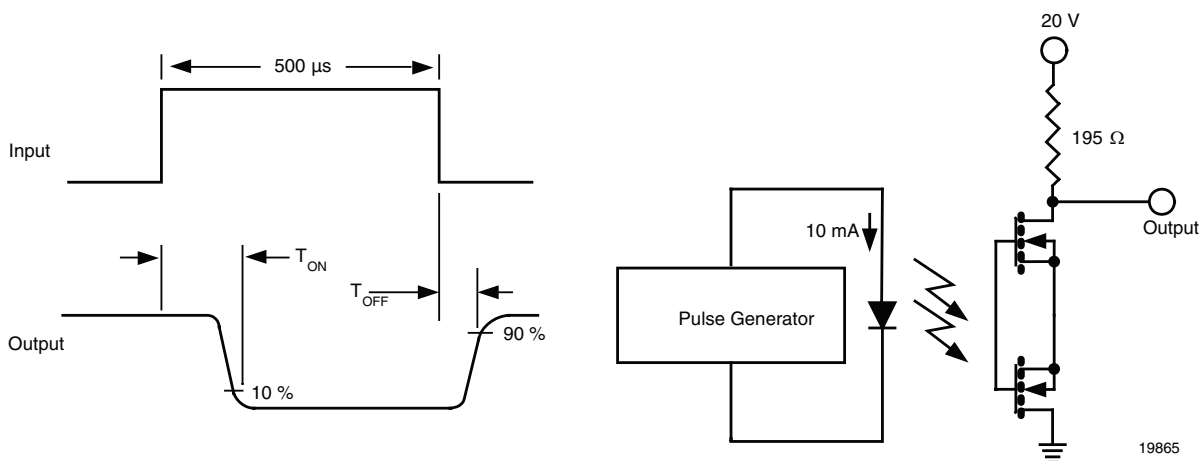

Safety and Insulation Ratings

This SSR is suitable for "safe electrical insulation" only within the safety ratings. Compliance with the safety ratings shall be ensured by means of protective circuits.

Parameter	Symbol	Value	Units	Conditions
Climatic Classification		40/85/21		IEC 68 part 1
Pollution Degree		2		DIN VDE 0109
Tracking resistance (Comparative Tracking Index)	CTI	175		Insulation group IIIa
Highest allowable overvoltage	V_{IOTM}	6000	V_{peak}	Transient overvoltage
Maximum working insulation voltage	V_{IORM}	707	V_{peak}	Recurring peak voltage
Insulation resistance at 25 °C	R_{IS}	$\geq 10^{12}$	Ω	$V_{IO} = 500 V$
Insulation resistance at T_S	R_{IS}	$\geq 10^9$	Ω	$V_{IO} = 500 V$
Insulation resistance at 100 °C	R_{IS}	$\geq 10^{11}$	Ω	$V_{IO} = 500 V$
Partial discharge test voltage	V_{pd}	1325	V_{peak}	Method a, $V_{pd} = V_{IORM} \times 1.875$
Isolation test voltage, 1 second	V_{rms}	1800	V_{rms}	
Safety limiting values - Maximum values allowed in the event of a failure				
Case temperature	T_{SI}	165	°C	
Input current	I_{SI}	150	mA	
Output power	P_{SO}	400	mW	
Minimum external air gap (Clearance)		≥ 5	mm	Measured from input terminals to output terminals, shortest distance through air
Minimum external tracking (Creepage)		≥ 5	mm	Measured from input terminals to output terminals, shortest distance path long body

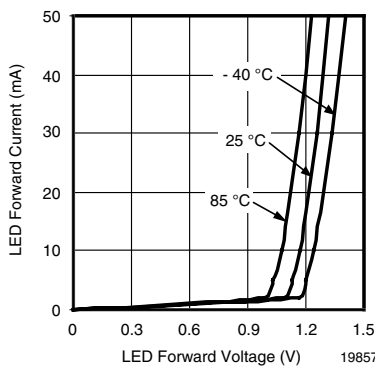

Figure 2. Typical LED Forward Voltage vs. Current

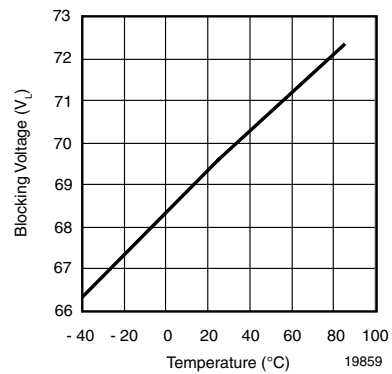

Figure 3. Typical Blocking Voltage vs. Temperature

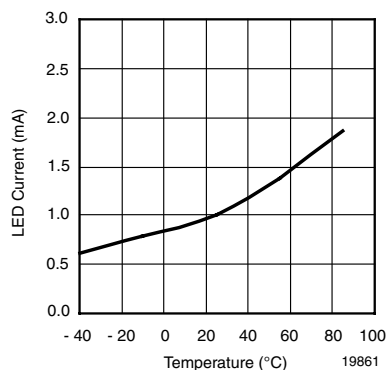

Figure 4. Typical I_F For Switch Operation vs. Temperature (Load Current = 100 mA)

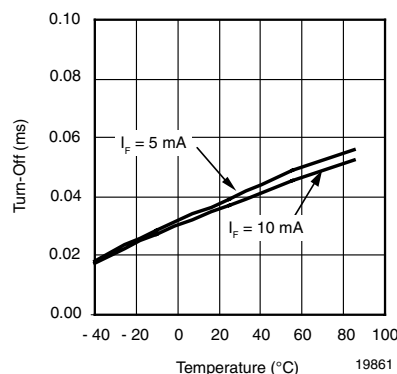

Figure 7. Typical Turn-Off vs. Temperature (Load Current = 100 mA)

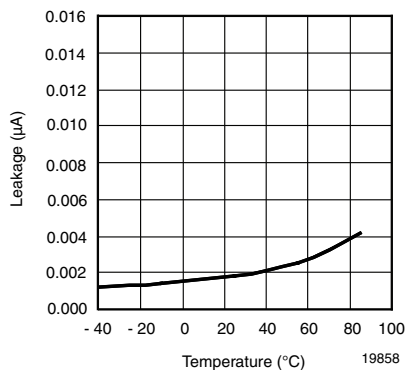

Figure 5. Typical Leakage vs. Temperature ($V_L = 60$ V)

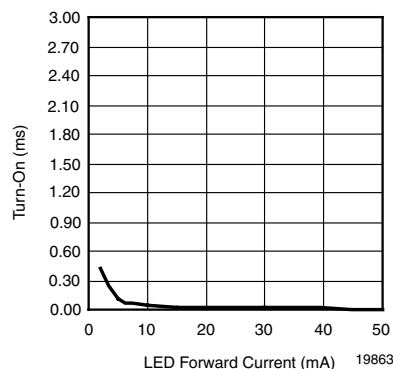

Figure 8. Typical Turn-On vs. LED Forward Current (Load Current = 100 mA)

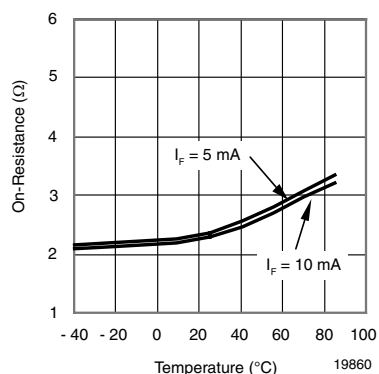

Figure 6. Typical On-Resistance vs. Temperature (Load Current = 100 mA)

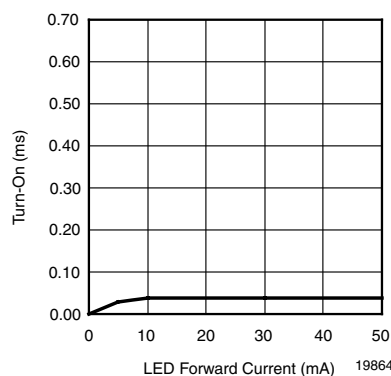
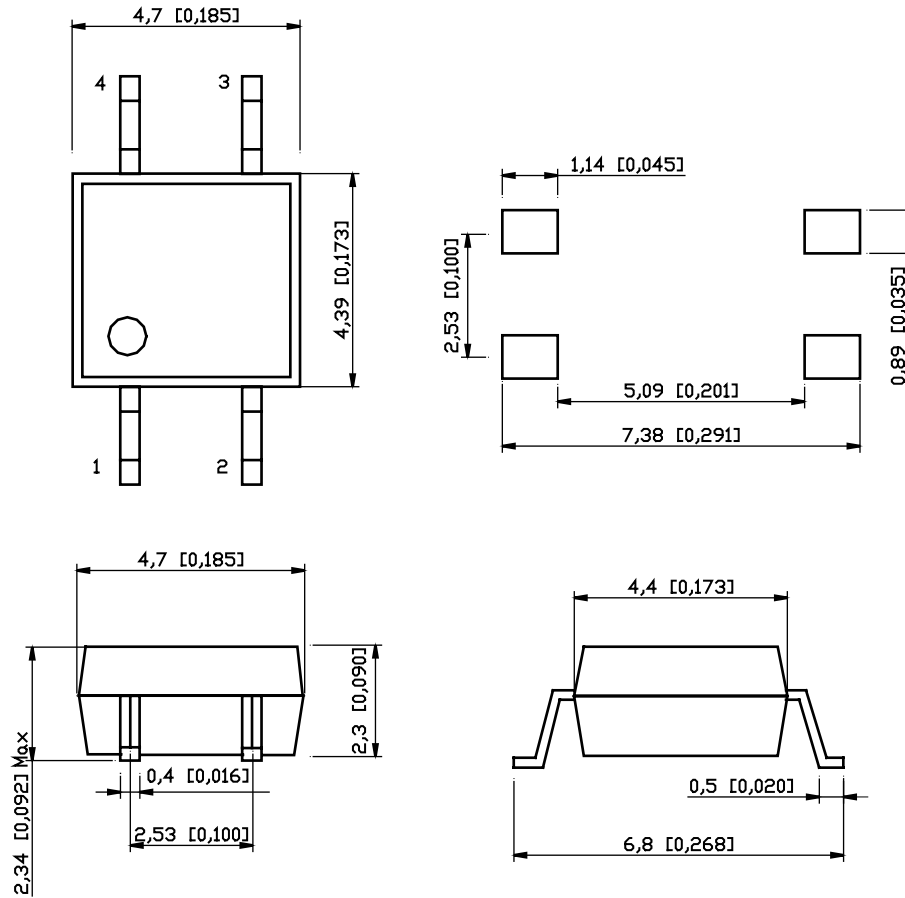

Figure 9. Typical Turn-Off vs. LED Forward Current (Load Current = 100 mA)

Package Dimensions in mm (Inches)



19410

ESD Caution

This is an ESD (electro static discharge) sensitive device. Electrostatic charges accumulate on the human body and test equipment and can discharge without detection. Therefore, proper ESD precautions are recommended to avoid performance degradation or loss of functionality. ESD withstand voltage of this device is up to 1500 V acc. to JESD22-A114-B.



20055

Ozone Depleting Substances Policy Statement

It is the policy of Vishay Semiconductor GmbH to

1. Meet all present and future national and international statutory requirements.
2. Regularly and continuously improve the performance of our products, processes, distribution and operating systems with respect to their impact on the health and safety of our employees and the public, as well as their impact on the environment.

It is particular concern to control or eliminate releases of those substances into the atmosphere which are known as ozone depleting substances (ODSs).

The Montreal Protocol (1987) and its London Amendments (1990) intend to severely restrict the use of ODSs and forbid their use within the next ten years. Various national and international initiatives are pressing for an earlier ban on these substances.

Vishay Semiconductor GmbH has been able to use its policy of continuous improvements to eliminate the use of ODSs listed in the following documents.

1. Annex A, B and list of transitional substances of the Montreal Protocol and the London Amendments respectively
2. Class I and II ozone depleting substances in the Clean Air Act Amendments of 1990 by the Environmental Protection Agency (EPA) in the USA
3. Council Decision 88/540/EEC and 91/690/EEC Annex A, B and C (transitional substances) respectively.

Vishay Semiconductor GmbH can certify that our semiconductors are not manufactured with ozone depleting substances and do not contain such substances.

We reserve the right to make changes to improve technical design
and may do so without further notice.

Parameters can vary in different applications. All operating parameters must be validated for each customer application by the customer. Should the buyer use Vishay Semiconductors products for any unintended or unauthorized application, the buyer shall indemnify Vishay Semiconductors against all claims, costs, damages, and expenses, arising out of, directly or indirectly, any claim of personal damage, injury or death associated with such unintended or unauthorized use.

Vishay Semiconductor GmbH, P.O.B. 3535, D-74025 Heilbronn, Germany



Notice

Specifications of the products displayed herein are subject to change without notice. Vishay Intertechnology, Inc., or anyone on its behalf, assumes no responsibility or liability for any errors or inaccuracies.

Information contained herein is intended to provide a product description only. No license, express or implied, by estoppel or otherwise, to any intellectual property rights is granted by this document. Except as provided in Vishay's terms and conditions of sale for such products, Vishay assumes no liability whatsoever, and disclaims any express or implied warranty, relating to sale and/or use of Vishay products including liability or warranties relating to fitness for a particular purpose, merchantability, or infringement of any patent, copyright, or other intellectual property right.

The products shown herein are not designed for use in medical, life-saving, or life-sustaining applications. Customers using or selling these products for use in such applications do so at their own risk and agree to fully indemnify Vishay for any damages resulting from such improper use or sale.